



1. Feature

- ▶ High Performance
- ▶ High Reliability
- ▶ RoHS Compliant

Highpass Filter

Part No: CHF07000M18000A01

Date: June.1th.2018

Revision No: Preliminary

2. Electrical Specifications

Parameter	Specification	Remark
Pass Band	7000-18000MHz	
Rejection	≥40dB@DC-6.5GHZ	
Insertion loss	≤2.0dB	
VSWR	≤2.0	
Average Power	≤10W	
Impedance	50Ω	

3. Mechanical Specifications

Parameter	Specifications	Remark
Dimensions	40.0 x 22.0 x 12.0 mm (Not including the tuning screws and connectors)	
Connector Type	SMA- Female (Stainless Steel)	
Surface Finish	Grey Painting	

4. Temperature Specifications

Parameter	Specifications	Remark
Operational Temperature	-40 to +80 °C	
Storage Temperature	-55 to +85 °C	

4. Outline Drawing ($\pm 0.5\text{mm}$)



CONCEPT

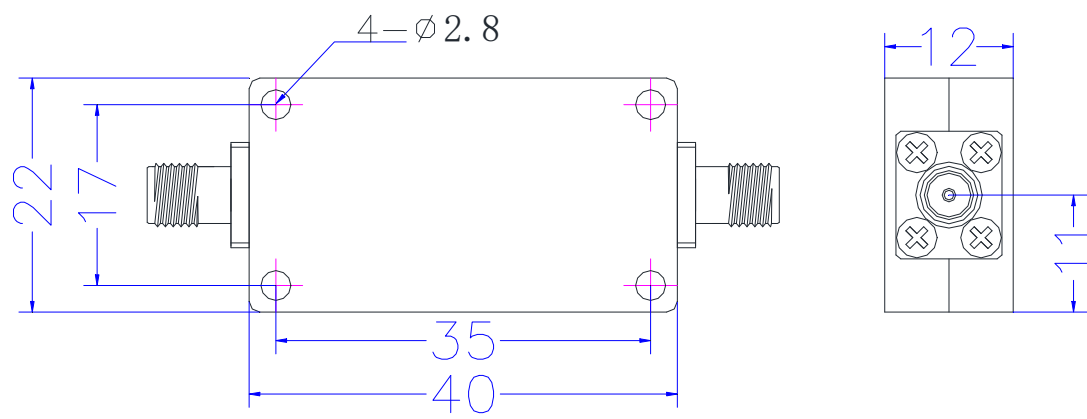

6. Test Curve

