



1. Feature

- ▶ High Performance
- ▶ High Reliability
- ▶ RoHS Compliant

Power Divider

Part No: CPD00500M08000A02

Date: March.15th.2018

Revision No: Preliminary

2. Electrical Specifications

Parameter	Specification	Remark
Frequency Range	500-8000MHz	
Insertion loss	≤1.50dB	
VSWR	≤1.50 (Input) ≤1.30 (Output)	
Amplitude Balance	≤±0.3dB	
Phase Balance	≤±3degree	
Isolation	≥20dB	
Average Power	30W (Forward) 1W (Reverse)	
Impedance	50Ω	

3. Mechanical Specifications

Parameter	Specifications	Remark
Dimensions	56.0x30.0x10.0mm	
Connector Type	SMA-female	
Surface Finish	Grey Painting	

4. Temperature Specifications

Parameter	Specifications	Remark
Operational Temperature	-40 to +80 °C	
Storage Temperature	-45 to +85 °C	

成都康普信源科技有限公司

Chengdu Concept Microwave Technology CO.,Ltd

No.666 ,Jinfenghuang Road , CREC Industrial Park , Jinniu District , Chengdu , China

E-mail: sales@concept-mw.com

<http://www.concept-mw.com>

Page 1 of 3

*Professional manufacturer of
passive microwave components*

DN: CN0195-March./15th/2018

Technical Specifications

5. Outline Drawing ($\pm 0.3\text{mm}$)



CONCEPT

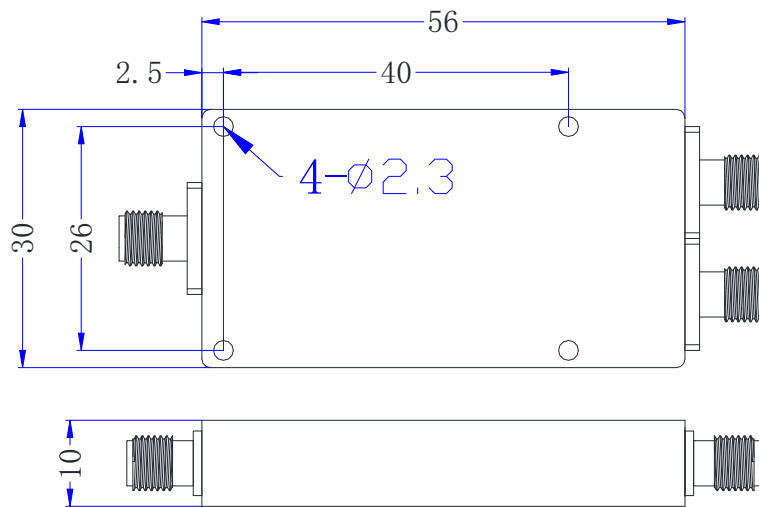

成都康普信源科技有限公司

Chengdu Concept Microwave Technology CO.,Ltd

No.666 ,Jinfenghuang Road , CREC Industrial Park , Jinniu District , Chengdu , China

E-mail: sales@concept-mw.com

<http://www.concept-mw.com>

Page 2 of 3

6. Test Curve



VSWR , I.L , Amplitude , Phase Balance

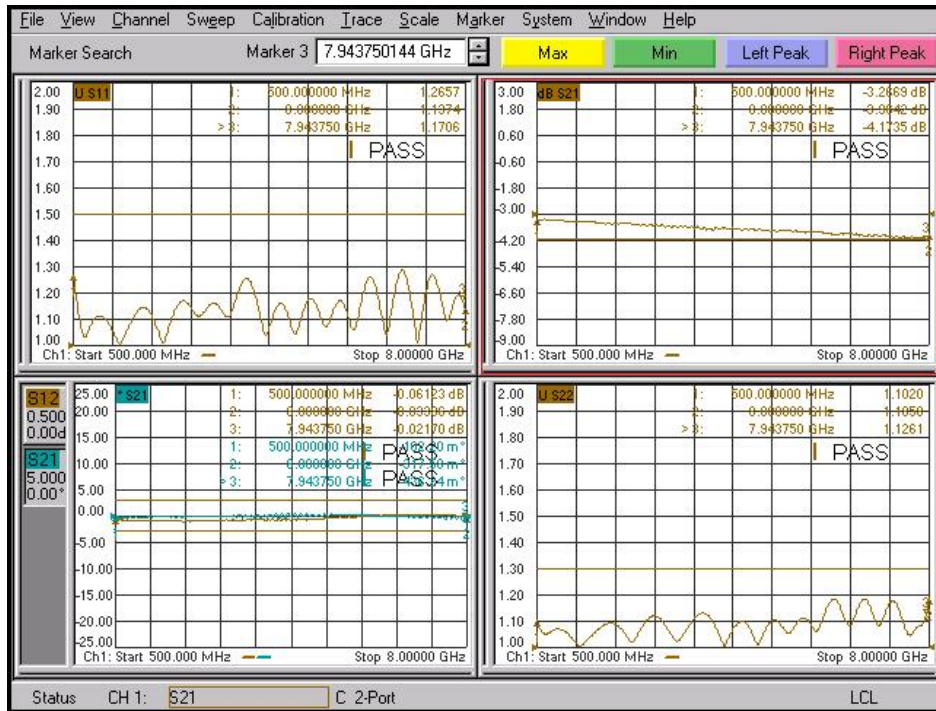

Isolation

